

3-M2 depth 5

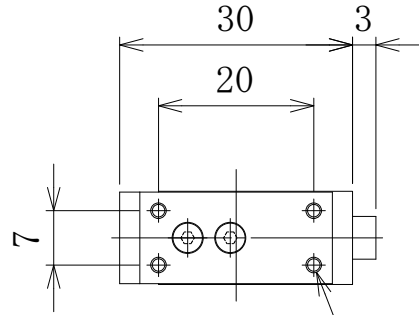

4-M2 depth 3

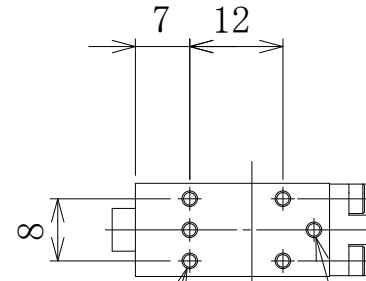
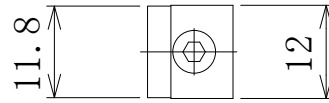

4-M2 depth 3

Hole for fabrication,  
not for user

2 × 2-M2 depth 2.5

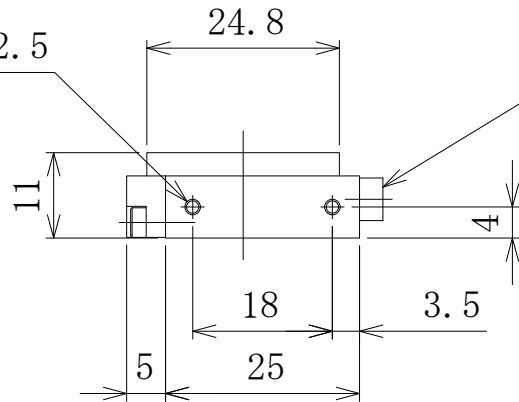

Feed screw  
(by hex wrench 2.5)